



MARTIN STONE

MARTIN STONE

Bienvenidos a Martin Stone

Desde 1969, Martin Stone atesora una larga tradición en el sector de la fabricación de material sintético. Es una empresa de referencia, líder en producción tanto a nivel nacional como internacional.

En 2006 se realiza la más importante ampliación de la empresa, creándose la línea de producto Sintextone, siguiendo así la tendencia del sector hacia una renovación en los sistemas constructivos. Esta implantación conduce la trayectoria de la empresa hacia materiales cada vez más eficientes y respetuosos con el medio ambiente.

En un mercado cada vez más competitivo y exigente, Martin Stone apostando por la calidad y la innovación de sus productos, contando con una línea de producción propia, capaz de fabricar cualquier clase de material que pueda necesitar el cliente, cubriendo así las más exclusivas.

La empresa cuenta con un departamento permanentemente de I+D (Investigación y Desarrollo) que la hace ser más competitiva y exigente con el producto final, adaptándose así a los constantes cambios del mercado.

Martin Stone has gained since 1969 a long tradition in the field of manufacturing of synthetic materials. This is a reference company, a manufacturing leader both at national and international level.

*The Company implemented in 2006 the most important company extension, creating the **Sintextone** product line, thus following the industry trend towards a renewal of the constructive systems.*

This implementation led the Company towards increasingly more efficient and environmentally friendly materials.

*In an increasingly competitive and demanding market, **Martin Stone** has bet on quality and innovation of its products, adding its own manufacturing line capable of producing any material our customers may need, satisfying even the most demanding wishes.*

The company has its own stable R+D department, which allows the Company to be more competitive and demanding with the final product, thus adapting the Company to the continuous market changes.

Dal 1969, **Martin Stone** fa tesoro di una lunga tradizione nel settore della produzione di materiale sintetico. E' un'azienda di riferimento, leader nella produzione sia a livello nazionale che internazionale.

Nel 2006, si realizza la più importante espansione aziendale, grazie alla creazione della linea di prodotto **Sintextone**, seguendo così la tendenza del settore verso un rinnovamento nei sistemi di costruzione. Questa implementazione guida l'azienda verso materiali sempre più efficienti in grado di rispettare l'ambiente.

In un mercato sempre più competitivo ed esigente, **Martin Stone** scommette sulla qualità e sull'innovazione dei suoi prodotti, con una linea di produzione propria in grado di effettuare qualsiasi tipo di materiale che può richiedere al cliente, che copre il più esclusivo.

L'azienda ha una R & S (Ricerca e Sviluppo) permanente che lo rende più competitivo ed esigente con il prodotto finale, quindi adattarsi al mercato che cambia.

Martin Stone possède, depuis 1969, une longue tradition dans le secteur de la fabrication de matériau synthétique. Il s'agit d'une entreprise de référence, leader en production tant au niveau national qu'international.

*En 2006, le développement le plus important de l'entreprise est réalisé et la ligne de produit **Sintextone** est créée afin de suivre ainsi la tendance du secteur vers un renouvellement des systèmes de construction. Cette implantation mène la trajectoire de l'entreprise vers des matériaux toujours plus efficaces et respectueux de l'environnement.*

Martin Stone, du fait d'un marché toujours plus compétitif et exigeant, mise sur la qualité et l'innovation de ses produits, à partir d'une ligne de production propre, capable de fabriquer tout type de matériel selon les besoins du client et couvrant ainsi les demandes les plus exclusives.

La société a une R & D permanente (Recherche et Développement) qui le rend plus compétitif et exigeant avec le produit final, donc l'adaptation à l'évolution du marché.





PRAGA



PRAGA

■ Medidas Disponibles

Available Measures / Misure Disponibili / Mesures Disponibles

Ancho (cm.)

Available width (cm)
Larghezza disponibile (cm)
Largeur disponible (cm)

70 | 80 | 90 | 100

Largo (cm.)

Available length (cm)
Lunghezza disponibile (cm)
Longueur disponible (cm)

90 | 100 | 120 | 140 | 150 | 160 | 180 | 190 | 200

■ Medidas Técnicas

Technical Measures / Misure Disponibili / Mesures Techniques

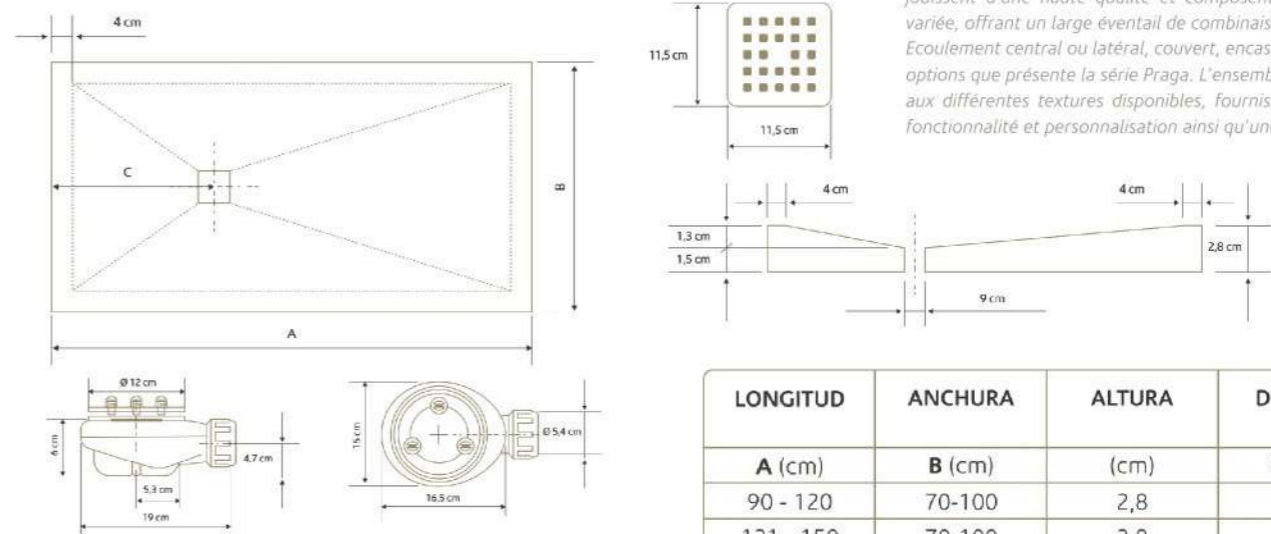

LONGITUD	ANCHURA	ALTURA	DESAGÜE
A (cm)	B (cm)	(cm)	C (cm)
90 - 120	70-100	2,8	25
121 - 150	70-100	2,8	30
151 - 200	70-100	2,8	60

■ Acabados

Finishes / Finiture / Finitions



RAL 9003
Blanco
White
Bianco
Blanc

RAL 1015
Crema
Cream
Crema
Crème

RAL 7004
Gris
Grey
Grigio
Gris

RAL 7015
Gris oscuro
Dark grey
Grigio scuro
Gris foncé

RAL 8007
Chocolate
Chocolate
Cioccolato
Chocolat

RAL 1019
Tierra
Earth
Terra
Terre

RAL 9005
Negro
Black
Nero
Noir

DIÁMETRO DESAGÜE = 9 cm

■ Textura

Texture / Consistenza / Texture



Pizarra
Slate
Ardesia
Ardoise

MARTIN STONE

La serie de platos de ducha Praga, diseñados y fabricados por Martin Stone, es la más completa. Sus modernas y minimalistas piezas de alta calidad componen una gama de lo más variado, ofreciendo un amplio abanico de combinaciones y posibilidades. Desagüe central o lateral, aplacado, enmarcado, o forma angular son las opciones con las que se presenta la serie Praga. La suma de estos elementos unidos a las diferentes texturas disponibles, proporcionan un alto grado de funcionalidad y personalización, con una estética depurada.

The Praga collection of shower trays, designed and manufactured in Martin Stone, is the most comprehensive one. Its modern and minimalist, high quality pieces, constitute a range of high variety, offering a wide range of combinations and possibilities. Central or lateral drainpipe, framed or in angular shape are the options in which the Praga collection is presented. The sum of these elements, together with the different textures available, offer a high degree of functionality and customization with a refined aesthetic.

La serie di piatti doccia Praga, progettati e prodotti da Martin Stone, è la più completa. I suoi pezzi di alta qualità moderni e minimalisti, compongono una gamma varia e offrono un ampio ventaglio di combinazioni e possibilità. Caditoia centrale o laterale, rivestimento, incorniciatura o forma angolare: ecco le opzioni con le quali si presenta la serie Praga. La somma di questi elementi insieme alle diverse texture disponibili, conferisce un alto grado di funzionalità e personalizzazione, con un'estetica depurata.

La série des plateaux de douche Praga, conçus et fabriqués par Martin Stone, est la plus complète. Ses pièces modernes et minimalistes jouissent d'une haute qualité et composent une gamme des plus variées, offrant un large éventail de combinaisons et de possibilités. Ecoulement central ou latéral, couvert, encastré ou en angle sont les options que présente la série Praga. L'ensemble de ces éléments unis aux différentes textures disponibles, fournissent un haut degré de fonctionnalité et personnalisation ainsi qu'une esthétique épurée.



ROMA



ROMA

■ Medidas Disponibles

Available Measures / Misure Disponibili / Mesures Disponibles

Ancho (cm.)

Available width (cm)
Larghezza disponibile (cm)
Largeur disponible (cm)

70 | 80 | 90 | 100

Largo (cm.)

Available length (cm)
Lunghezza disponibile (cm)
Longueur disponible (cm)

90 | 100 | 120 | 140 | 150 | 160 | 180 | 190 | 200

■ Medidas Técnicas

Technical Measures / Misure Disponibili / Mesures Techniques

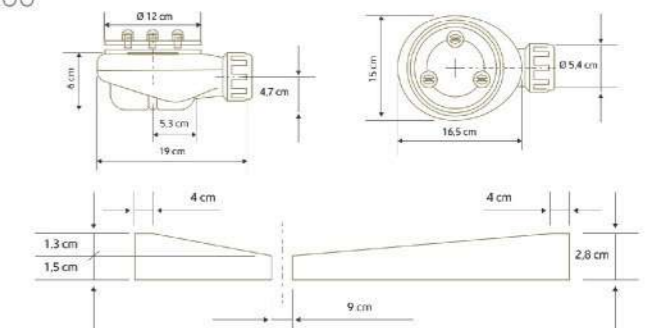
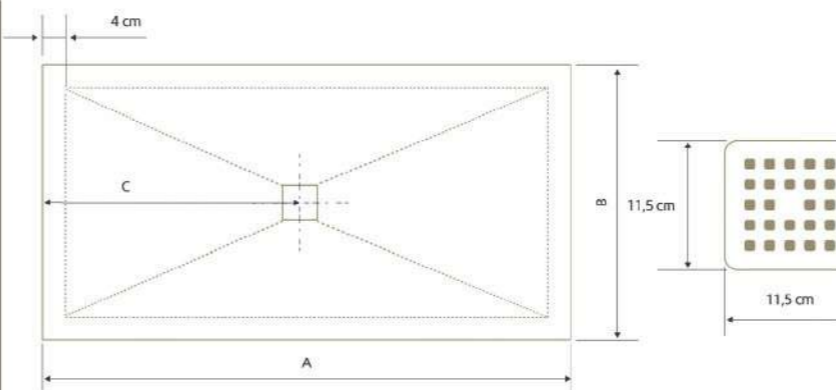

LONGITUD	ANCHURA	ALTURA	DESAGÜE
A (cm)	B (cm)	(cm)	C (cm)
90 - 120	70-100	2,8	25
121 - 150	70-100	2,8	30
151 - 200	70-100	2,8	60

DIÁMETRO DESAGÜE = 9 cm

■ Acabados

Finishes / Finiture / Finitions

RAL 9003 Blanco White Bianco Blanc	RAL 1015 Crema Cream Crema Crème	RAL 7004 Gris Grey Grigio Gris	RAL 7015 Gris oscuro Dark grey Grigio scuro Gris foncé	RAL 8007 Chocolate Chocolate Cioccolato Chocolat	RAL 1019 Tierra Earth Terra Terre	RAL 9005 Negro Black Nero Noir

■ Textura

Texture / Consistenza / Texture



Pizarra
Slate
Ardesia
Ardoise

MARTIN STONE



COOPENHAGEN

COPENHAGUE

■ Medidas Disponibles

Available Measures / Misure Disponibili / Mesures Disponibles

Ancho (cm.)

Available width (cm)
Larghezza disponibile (cm)
Largeur disponible (cm)

70 | 80 | 90

Largo (cm.)

Available length (cm)
Lunghezza disponibile (cm)
Longueur disponible (cm)

100 | 120 | 140 | 160 | 180

■ Medidas Técnicas

Technical Measures / Misure Disponibili / Mesures Techniques

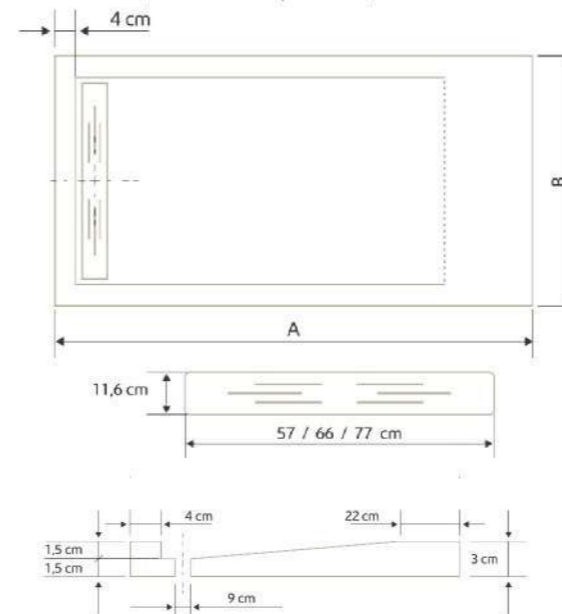

LONGITUD	ANCHURA	ALTURA	REJILLA
A (cm)	B (cm)	(cm)	(cm)
100	70 / 80 / 90	3	57 / 66 / 77
120	70 / 80 / 90	3	57 / 66 / 77
140	70 / 80 / 90	3	57 / 66 / 77
160	70 / 80 / 90	3	57 / 66 / 77
180	70 / 80 / 90	3	57 / 66 / 77

DIÁMETRO DESAGÜE = 9 cm

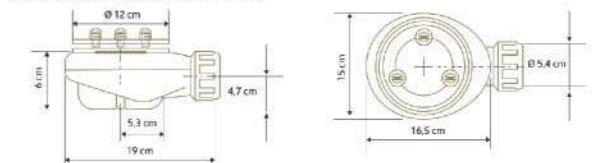

■ Acabados

Finishes / Finiture / Finitions



RAL 9003
Blanco
White
Bianco
Blanc

RAL 1015
Crema
Cream
Crema
Crème

RAL 7004
Gris
Grey
Grigio
Gris

RAL 7015
Gris oscuro
Dark grey
Grigio scuro
Gris foncé

RAL 8007
Chocolate
Chocolate
Cioccolato
Chocolat

RAL 1019
Tierra
Earth
Terra
Terre

RAL 9005
Negro
Black
Nero
Noir

■ Textura

Texture / Consistenza / Texture



Pizarra
Slate
Ardesia
Ardoise

MARTIN STONE

La serie de platos de ducha Copenhagen nace como fiel reflejo de la serie Ankara. También formada por contraste entre el acero y las superficies sólidas, la serie de platos de ducha Copenhagen construye con sus finas líneas un espacio donde el agua fluye por su textura de pizarra hasta llegar a desembocar en el acero, dotando al conjunto de una bella armonía.

Al igual que la serie Ankara, es personalizable a través de numerosos colores.

The Copenhagen collection of shower trays was born as the true reflect of the Ankara Collection. Also configured with the contrast between steel and the solid surfaces, the Copenhagen collection of shower trays constitutes with its fine lines a space on which water flows over its slate texture until it disemboque on the steel, giving the whole set beautiful harmony.

Like the Ankara Collection, it can be customized thanks to numerous colours.

La serie di piatti doccia Copenhagen nasce come fedele riflesso della serie Ankara. Anch'essa formata dal contrasto fra acciaio e superfici solide, la serie di piatti doccia Copenhagen costruisce con le sue sottili linee, uno spazio nel quale l'acqua scorre attraverso la sua texture di ardesia fino ad arrivare a sfociare nell'acciaio, dotando la composizione di una bella armonia.

Analogamente alla serie Ankara, è personalizzabile in numerosi colori.

La série des plateaux de douche Copenhagen n'est autre que le fidèle reflet de la série Ankara. Egalement le produit du contraste entre l'acier et les surfaces solides, la série des plateaux de douche Copenhagen construit avec ses lignes fines un espace où l'eau coule le long de sa texture d'ardoise pour se déverser dans l'acier et donner à l'ensemble une belle harmonie.

De même que la série Ankara, elle est personnalisable grâce à de nombreuses couleurs.



PISA

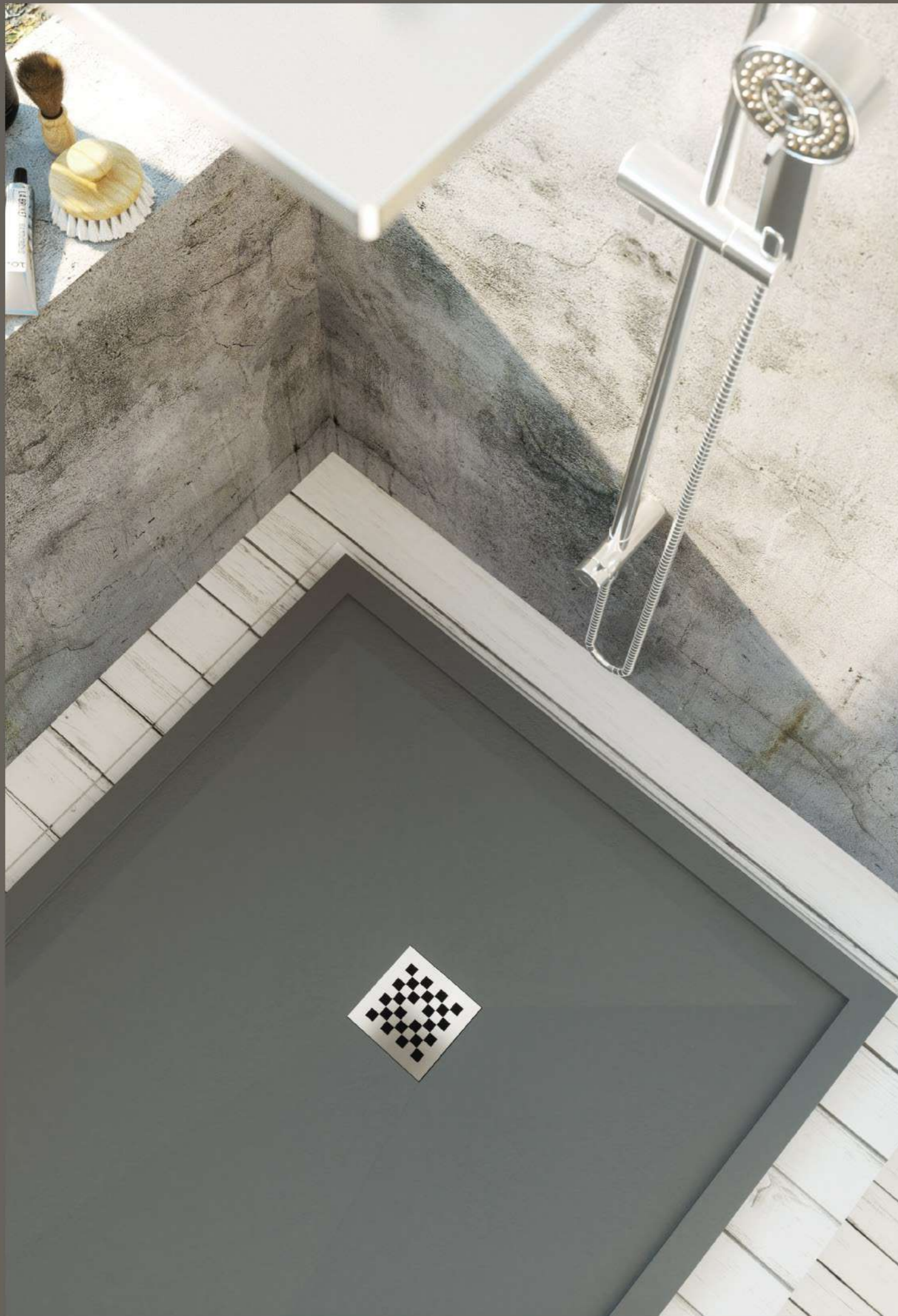

PISA

■ Medidas Disponibles

Available Measures / Misure Disponibili / Mesures Disponibles

Ancho (cm.)

Available width (cm)
Larghezza disponibile (cm)
Largeur disponible (cm)

70 | 80 | 90 | 100

Largo (cm.)

Available length (cm)
Lunghezza disponibile (cm)
Longueur disponible (cm)

90 | 100 | 120 | 140 | 150 | 160 | 180 | 190 | 200

■ Medidas Técnicas

Technical Measures / Misure Disponibili / Mesures Techniques

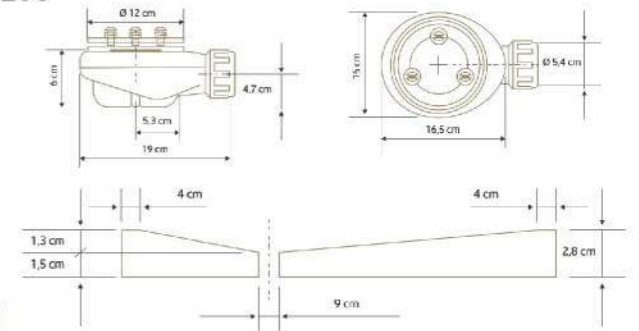
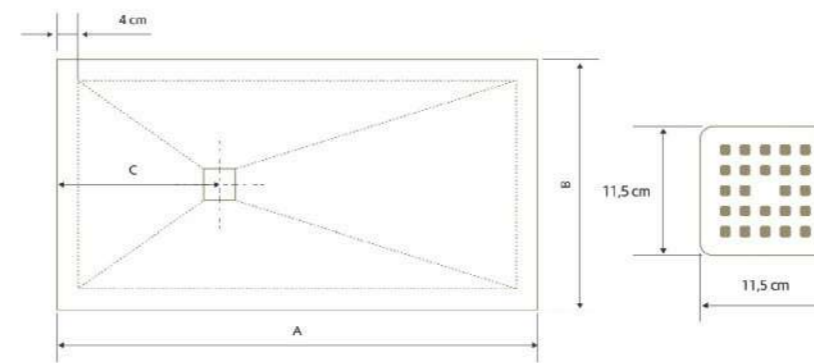

LONGITUD	ANCHURA	ALTURA	DESAGÜE
A (cm)	B (cm)	(cm)	C (cm)
90 - 120	70-100	2,8	25
121 - 150	70-100	2,8	30
151 - 200	70-100	2,8	60

■ Acabados

Finishes / Finiture / Finitions

DIÁMETRO DESAGÜE = 9 cm

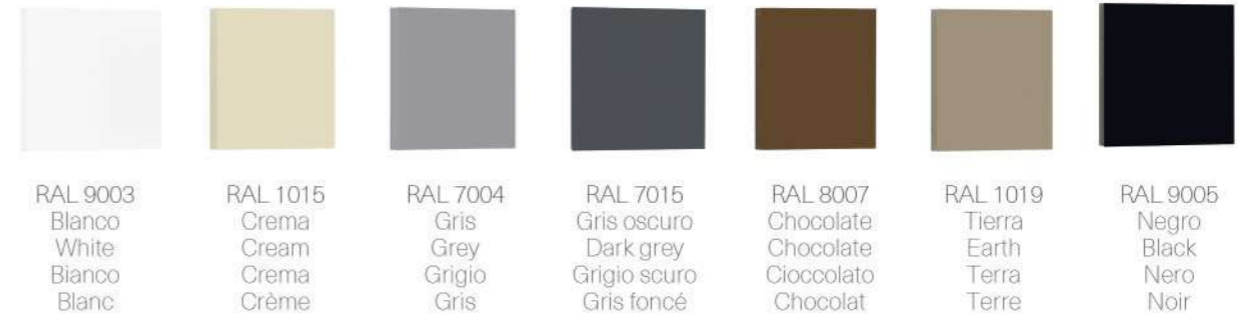

RAL 9003
Blanco
White
Bianco
Blanc

RAL 1015
Crema
Cream
Crema
Crème

RAL 7004
Gris
Grey
Grigio
Gris

RAL 7015
Gris oscuro
Dark grey
Grigio scuro
Gris foncé

RAL 8007
Chocolate
Chocolate
Cioccolato
Chocolat

RAL 1019
Tierra
Earth
Terra
Terre

RAL 9005
Negro
Black
Nero
Noir

■ Textura

Texture / Consistenza / Texture



Pizarra
Slate
Ardesia
Ardoise

MARTIN STONE



BAHÍA



BAHÍA

■ Medidas Disponibles

Available Measures / Misure Disponibili / Mesures Disponibles

Ancho (cm.)

Available width (cm)
Larghezza disponibile (cm)
Largeur disponible (cm)

70 | 80 | 90 | 100

Largo (cm.)

Available length (cm)
Lunghezza disponibile (cm)
Longueur disponible (cm)

90 | 100 | 120 | 140 | 150 | 160 | 180 | 190 | 200

■ Medidas Técnicas

Technical Measures / Misure Disponibili / Mesures Techniques

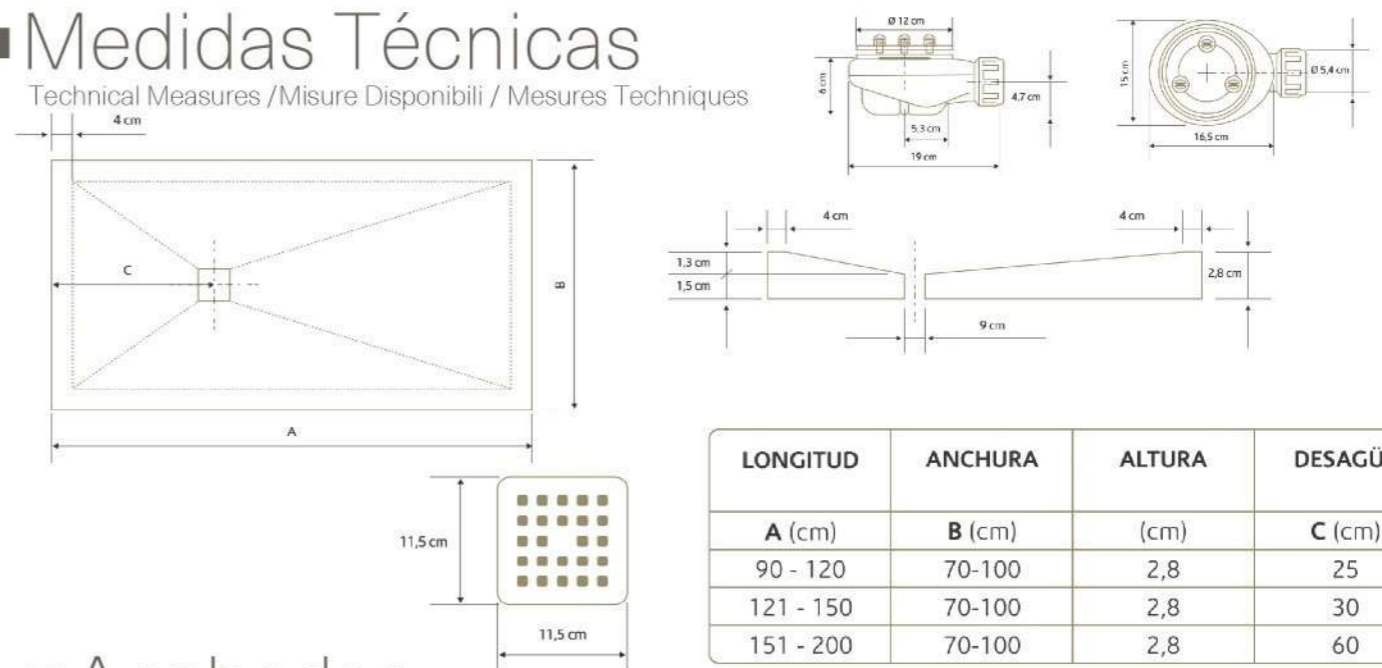

LONGITUD	ANCHURA	ALTURA	DESAGÜE
A (cm)	B (cm)	(cm)	C (cm)
90 - 120	70-100	2,8	25
121 - 150	70-100	2,8	30
151 - 200	70-100	2,8	60

■ Acabados

Finishes / Finiture / Finitions

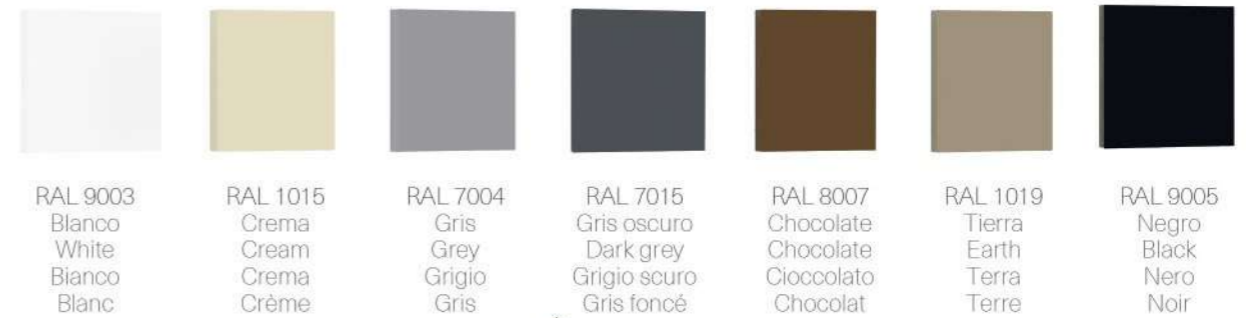

DIÁMETRO DESAGÜE = 9 cm

■ Textura

Texture / Consistenza / Texture



Madera
Wood
Legno
Bois

MARTIN STONE



BAKU



BAKÚ

ATENAS

■ Medidas Disponibles

Available Measures / Misure Disponibili / Mesures Disponibles

Ancho (cm.)

Available width (cm)
Larghezza disponibile (cm)
Largeur disponible (cm)

40 | 40 | 15



Medida (cm):
Size (cm):
Misure (cm):
Mesures (cm):

Ø45 x 15

■ Medidas Técnicas

Technical Measures / Misure Disponibili / Mesures Techniques

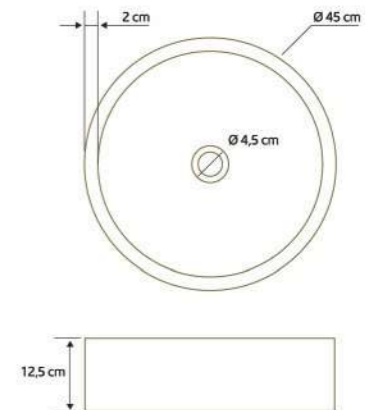
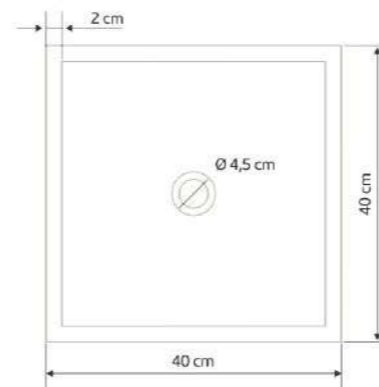

■ Acabados

Finishes / Finiture / Finitions



RAL 9003
Blanco
White
Bianco
Blanc



RAL 1015
Crema
Cream
Crema
Crème



RAL 7004
Gris
Grey
Grigio
Gris



RAL 7015
Gris oscuro
Dark grey
Grigio scuro
Gris foncé



RAL 8007
Chocolate
Chocolate
Cioccolato
Chocolat



RAL 1019
Tierra
Earth
Terra
Terre



RAL 9005
Negro
Black
Nero
Noir

■ Textura

Texture / Consistenza / Texture

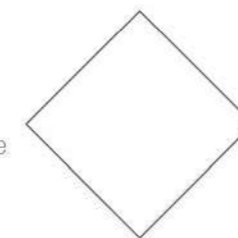

Lisa
Straight
Liscio
Lisse

MARTIN STONE



MONNACCO



MÓNACO

■ Medidas Disponibles

Available Measures / Misure Disponibili / Mesures Disponibles

Ancho (cm.) *Available width (cm)*
Larghezza disponibile (cm) | *Largeur disponible (cm)* | **Faldón (cm.)** *Gable*
 46 | 51 | *Cornice* | 12,5
Jupe

Largo (cm.) *Available length (cm)*
Lunghezza disponibile (cm) | *Longueur disponible (cm)*
 81 | 91 | 101 | 111 | 121 | 131 | 141 | 151 | 161 | 171 | 181 | 191

■ Medidas Técnicas

Technical Measures / Misure Disponibili / Mesures Techniques

Sin Faldón *Without gable / Senza cornice / Sans jupe* | **Con Faldón** *With gable / Con cornice / Avec jupe*

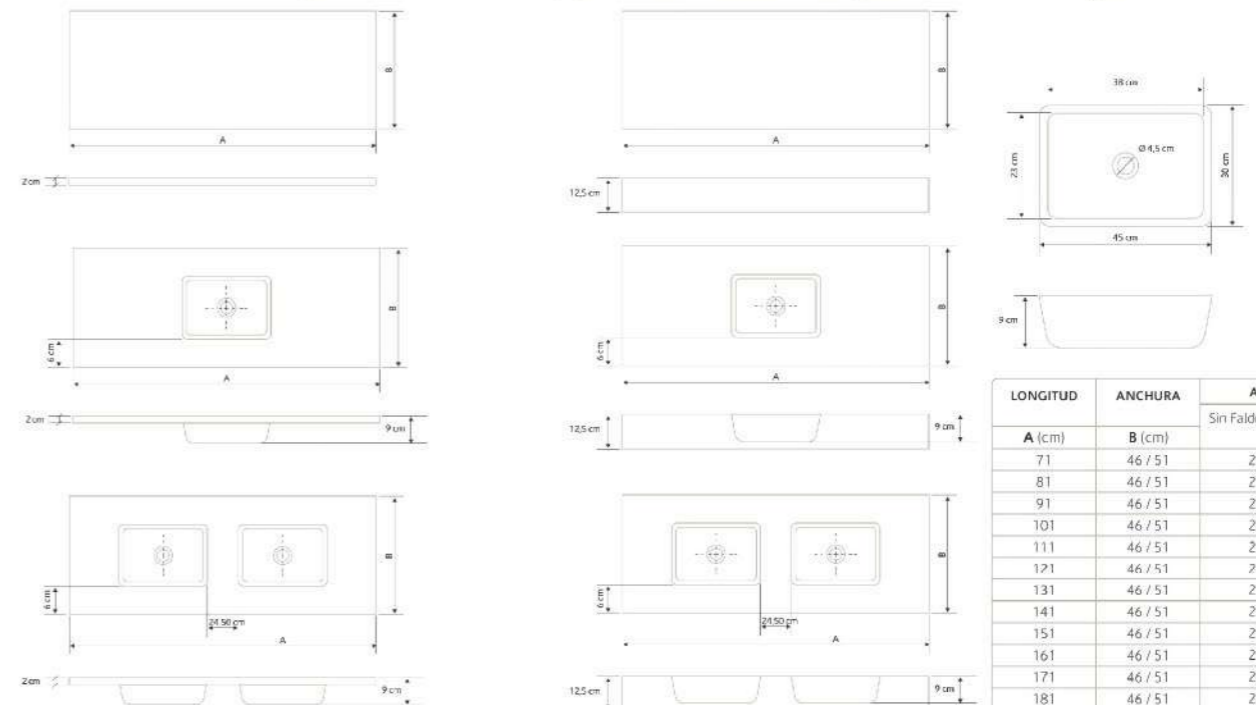

LONGITUD A (cm)	ANCHURA B (cm)	ALTURA	
		Sin Faldón (cm)	Con Faldón (cm)
71	46 / 51	2	12,5
81	46 / 51	2	12,5
91	46 / 51	2	12,5
101	46 / 51	2	12,5
111	46 / 51	2	12,5
121	46 / 51	2	12,5
131	46 / 51	2	12,5
141	46 / 51	2	12,5
151	46 / 51	2	12,5
161	46 / 51	2	12,5
171	46 / 51	2	12,5
181	46 / 51	2	12,5
191	46 / 51	2	12,5

DIÁMETRO DESAGÜE = 9 cm

■ Acabados

Finishes / Finiture / Finitions



■ Textura

Texture / Consistenza / Texture

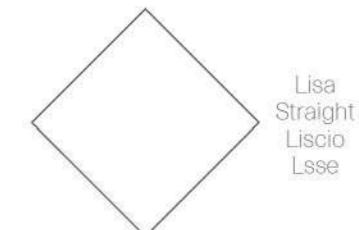

MARTIN STONE



■ Válvula
Valve
Valvola
Vanne

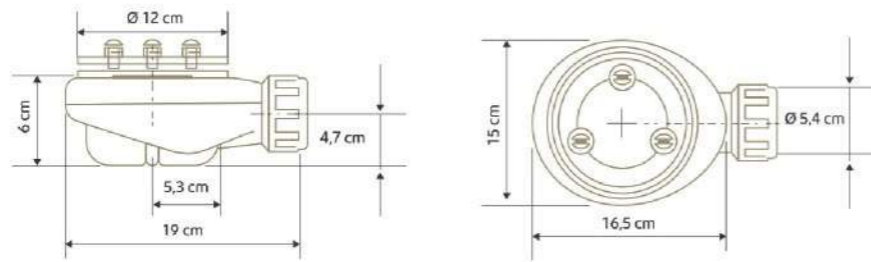

Sintextone

FICHAS TÉCNICAS / TECHNICAL DATA SHEETS

Es un material de alta calidad compuesto por una resina de poliéster combinado con áridos. Tiene una resistencia superior a un hormigón convencional 5 veces más fuerte, no lleva armadura lo que evita efectos cerca del mar.

Su facilidad de fabricación y amplia gama de colores son factores que posibilitan unos diseños innovadores. Se pueden fabricar en cualquier textura y color, obteniéndose la forma que se desee.

This is a high quality material made of a polyester resin combined with aggregates. It has 5x the resistance of conventional concrete and does not have reinforcement, thus avoiding negative effects close to the sea.

Its ease of manufacturing and the wide colour range are factors allowing innovative designs. It can be manufactured in any texture and colour, and any shape can be accomplished.

Propiedades de Sintextone / Properties of Sintextone

Mínima absorción de agua, facilita la evacuación de fluidos <i>Minimum water absorption, thus facilitating fluid evacuation</i>	Espesores estandarizados según aplicación y formato <i>Standard thicknesses depending on the application and the format</i>	Elevada resistencia al impacto y a la tensión <i>Large resistance to impacts and tension</i>
Gran variedad de acabados <i>Large variety of finishing</i>	Bajo coste de mantenimiento y fácil limpieza <i>Low maintenance cost and easy cleaning</i>	Colocación con cemento cola (flexible C2T) <i>Laying with cement glue (flexible C2T)</i>
Gran variedad de formatos y tamaños <i>Large variety of formats and sizes</i>	Más ligero, ahorro en el transporte y fácil colocación <i>Less weight; less transport cost and easy assembly</i>	Aplicaciones: pavimentos, revestimientos, escaleras, encimeras de baño, cenefas, marcos de puertas y ventanas, columnas, rodapiés, platos de ducha, etc. <i>Applications: pavements, coating, stairs, bathroom desktops, valances, door and window frames, columns, baseboards, shower trays, etc.</i>

Tabla de manchabilidad.
Resistencia química UNE-EN 14617-10:2012

Stainability table.
Chemical resistance UNE-EN 14617-10: 2012

PRODUCTOS TESTADOS TESTED PRODUCTS	TIEMPO DE EXPOSICIÓN / TIME OF EXPOSURE	
	8 horas / 8 hours	24 horas / 24 hours
ACEITE / OIL	NO	NO
GEL DE BAÑO / SHOWER GEL	NO	NO
CHAMPÚ / SHAMPOO	NO	NO
VINAGRE / VINEGAR	NO	NO
LECHE ENTERA / ENTIRE MILK	NO	NO
COCA-COLA / COCA-COLA	NO	NO
FREGASUELOS / FLOOR CLEANING LIQUIDS	NO	NO
CAFÉ / COFFEE	NO	NO
SALFUMAN / HYDROCHLORIC ACID	NO	NO
HIDRÓXIDO SÓDICO 0,5 N / SODIUM HYDROXIDE 0,5 N	NO	NO
LEJÍA / BLEACH	NO	NO
CERVEZA / BEER	NO	NO
VINO TINTO / RED WINE	NO	NO
LAVAVAJILLAS / DISHWASHER LIQUID	NO	NO
VIAKAL / VIAKAL	NO	NO
ALCOHOL 96° / ALCOHOL 96°	NO	NO
AGUA OXIGENADA / OXYGENATED WATER	NO	NO

Legenda: grado de afectación / Legend: degree of involvement

NO = NO AFECTADO / NO AFFECTED
I = LIGERAMENTE AFECTADO / SLIGHTLY AFFECTED
II = AFECTADO / AFFECTED

No utilizar para la limpieza acetona, disolventes, decapantes de pintura y estropajos metálicos. Se recomienda utilizar estropajos de plástico, tipo scott britte.

Do not use acetone for cleaning, solvents, paint strippers and steel wool. We recommend using plastic pads, britte type scott.

Características Técnicas
Technical Characteristics

ENSAYO / TEST	NORMA / NORM	RESULTADO MEDIO AVERAGE RESULT
RESISTENCIA A LA FLEXIÓN / RESISTANCE TO FLECTION	UNE-EN 14617-2:2005	13,5 Mpa F ₂
RESISTENCIA AL CHOQUE TÉRMICO / RESISTANCE TO THERMAL SHOCK	UNE-EN 14617-6:2005	17,3 Mpa
RESISTENCIA AL HIELO DESHIELO / RESISTANCE TO ICE-DEICING	UNE-EN 14617-5:2005	13,5 Mpa
ABSORCIÓN DE AGUA / WATER ABSORPTION	UNE-EN 14617-1:2005	0,069 % W ₂
COEFICIENTE DE DILATACIÓN TÉRMICA / COEFFICIENT OF THERMAL EXPANSION	UNE-EN ISO 10545/8	27,1 x 10 ⁶ °C
DENSIDAD APARENTE / APPARENT DENSITY	UNE-EN 14617-1:2005	2133 Kg/m ³
CONDUCTIVIDAD TÉRMICA / THERMAL CONDUCTIVITY	UNE-EN 12524:2000	= 1,3 W / (m. °k)
RESISTENCIA AL DESLIZAMIENTO / SLIP RESISTANCE	UNE-ENV 12633:2003	50 R ₉ > 45 Clase 3
RESISTENCIA A LA ABRASIÓN / ABRASION RESISTANCE	UNE-EN 14617-4:2012	27,5 mm A ₄ 29
RESISTENCIA QUÍMICA / CHEMICAL RESISTANCE	UNE-EN 14617-10:2012	Clasificación C ₄
		1ha5HCl 8ha30HCl 1ha5NaOH 8ha30NaOH SALFUMAN SODA CAUSTICA / HYDROCHLORIC ACID / CAUSTIC SODA no afectado / no affected no afectado / no affected

Propiedades / Properties

- 1 Antideslizamiento grado 3 / Anti-slip grade 3
- 2 Masa exterior y todo de un color / Exterior mass, one single colour
- 3 Textura natural / Natural texture

Sintextone

SCHEDE TECNICHE / FICHES TECHNIQUES

E' un materiale di alta qualità composto da una resina in poliestere combinato con inerti. Ha una resistenza superiore a un calcestruzzo convenzionale, 5 volte più forte, senza armatura per evitare effetti nei pressi del mare.

La sua semplicità di produzione e l'ampia gamma di colori sono i fattori che rendono possibili design innovativi. E' possibile realizzarli in qualsiasi texture e colore, nella forma desiderata.

Il s'agit d'un matériau de haute qualité composé d'une résine polyester mélangée à des agrégats. Il a une résistance cinq fois supérieure à celle du béton conventionnel, il ne comporte pas d'armature ce qui évite les effets près de la mer.

Sa simplicité de fabrication et sa large gamme de couleurs sont des facteurs qui rendent possible des conceptions innovatrices. Il peut être fabriqué dans toutes les couleurs et textures et permet d'obtenir ainsi la forme désirée.

Proprietà di Sintextone / Propriétés de Sintextone

Mínimo assorbimento di acqua, semplifica la fuoriuscita di fluidi <i>Une absorption de l'eau minimum facilite l'évacuation des fluides</i>	Spessori standardizzati secondo applicazione e formato <i>Epaisseurs standard selon l'application et le format</i>	Elevata resistenza all'impatto e alla tensione <i>Résistance élevée face aux chocs et la tension</i>
Grande varietà di finiture <i>Grand choix de finitions</i>	Basso costo di manutenzione e semplice da pulire <i>Coût minime de maintenance et de nettoyage facile</i>	Collocazione con cemento cola (flessibile C2T) <i>Pose au ciment colle (flexible C2T)</i>
Grande varietà di formati e dimensioni <i>Grande variété de formats et de tailles</i>	Più leggero, risparmio di trasporto e di semplice collocazione <i>Plus léger, économie de transport et facile à la pose.</i>	Applicazioni: pavimenti, rivestimenti, scale, top bagno, tendaggi, telai di porte e finestre, colonne, battiscopa, piatti doccia, ecc. <i>Applications: sols, revêtements, escaliers, comptoirs de salle de bain, plinthes, cadres de portes et fenêtres, colonnes, plinthes, plateaux de douche, etc.</i>

Tabella di macchiabilità.
Resistenza chimica UNE-EN 14617-10:2012

Tableau de salissures.
Résistance chimique UNE-EN 14617-10: 2012

PRODOTTI TESTATI PRODUITS TESTÉS	TEMPO DI ESPOSIZIONE / TEMPS D'EXPOSITION	
	8 ore / 8 heures	24 ore / 24 heures
OLIO / HUILE	NO / NON	NO / NON
GEL DOCCIA / GEL DE BAIN	NO / NON	NO / NON
SHAMPOO / SHAMPOO	NO / NON	NO / NON
ACETO / VINAIGRE	NO / NON	NO / NON
LATTE INTERO / LAIT ENTIER	NO / NON	NO / NON
COCA-COLA / COCA-COLA	NO / NON	NO / NON
SPAZZOLONI / NETTOYANT DE SOLS	NO / NON	NO / NON
CAFFÈ / CAFÉ	NO / NON	NO / NON
ACIDO CLORIDRICO / ACIDE CHLORHYDRIQUE	NO / NON	NO / NON
IDROSSIDO DI SODIO 0,5 N / HYDROXIDE SODIQUE 0,5N	NO / NON	NO / NON
CANDEGGINA / JAVEL	NO / NON	NO / NON
BIRRA / BIÈRE	NO / NON	NO / NON
VINO ROSSO / VIN ROUGE	NO / NON	NO / NON
DETERGENTE PERI PIATTI / NETTOYAN VAISSELLE	NO / NON	NO / NON
VIAKAL / VIAKAL	NO / NON	NO / NON
ALCOOL A 96° / ALCOOL À 96°	NO / NON	NO / NON
ACQUA OSSIGENATA / EAU OXYGENÉE	NO / NON	NO / NON

Legenda: grado di danno / Légende: degré d'affectation

NO / NON = NON DANNEGGIATO / PAS AFFECTÉ
I = LEGGERAMENTE DANNEGGIATO / LÉGÈREMENT AFFECTÉ
II = DANNEGGIATO / AFFECTÉ

No utilizzare per la pulizia acetone, solventi, svernicianti di pittura e pagliette di metallo. Si consiglia di utilizzare pagliette di plastica, tipo scott britte.
Pour son nettoyage, ne pas utiliser d'acétone, de dissolvants, de décapants pour peinture et de paille de fer. Il est recommandé d'utiliser des éponges en plastic, style Scotch Britte.

Caratteristiche Tecniche
Caractéristiques Techniques

ESPERIMENTO / ESSAIS	NORMA / NORME	RESULTATO MEDIO RÉSULTAT MOYEN
RESISTENZA ALLA FLESSIONE / RESISTANCE À LA FLEXION	UNE-EN 14617-2:2005	13,5 Mpa F ₂
RESISTENZA ALLO SHOCK TERMICO / RESISTANCE AU CHOC THERMIQUE	UNE-EN 14617-6:2005	17,3 Mpa
RESISTENZA AL GELO DISGELO / RESISTANCE AU GEL ET DÉGEL	UNE-EN 14617-5:2005	13,5 Mpa
ASSORBIMENTO DI ACQUA / ABSORPTION DE L'EAU	UNE-EN 14617-1:2005	0,069 % W ₂
COEFFICIENTE DI DILATAZIONE TERMICA / COEFFICIENT DE DILATATION THERMIQUE	UNE-EN ISO 10545/8	27,1 x 10 ⁶ °C
DENSITA' APPARENTE / DENSITÉ APPARENTE	UNE-EN 14617-1:2005	2133 Kg/m ³
CONDUCTIVITA' TERMICA / CONDUCTIVITÉ THERMIQUE	UNE-EN 12524:2000	= 1,3 W / (m. °k)
RESISTENZA ALLO SCIVOLAMENTO / RESISTANCE AU GLISSEMENT	UNE-ENV 12633:2003	50 R ₉ > 45 Clase 3
RESISTENZA ALL'ABRASIONE / ABRASION RESISTANCE	UNE-EN 14617-4:2012	27,5 mm A ₄ 29
RESISTENZA CHIMICA / RESISTANCE CHIMIQUE	UNE-EN 14617-10:2012	Clasificación C ₄
		1ha5HCl 8ha30HCl 1ha5NaOH 8ha30NaOH ACIDO CLORIDRICO SODA CAUSTICA / ACIDE CHLORHYDRIQUE / SODA CAUSTIQUE non danneggiato / pas affecté non danneggiato / pas affecté

Proprietà / Propriétés

- 1 Antiscivolamento grado 3 / Antidérapant de niveau 3
- 2 Massa esterna e tutto in un unico colore / Masse extérieure et tout d'une couleur
- 3 Texture naturale / Texture naturelle